

DAVCO WATERPROOFING GUIDE



Quality
Endorsed
Company
ISO 9001 LIC 10065
Standards Australia



Davco
EXCELLENCE IN
TILING SYSTEMS

Product Information



Type	Product	Description
Acrylics	<i>Dampflex</i>	A white, acrylic-based, non-trafficable waterproofing and sealing membrane ready to use from the container reinforced with fibreglass mat
	<i>Dampflex Reo</i>	An internally reinforced acrylic membrane which negates the need for external reinforcement at wall/floor junctions and areas to be waterproofed
	<i>Duraflex</i>	A single pack, water based, high build membrane coating for long-term protection of exterior surfaces. Duraflex can be applied to a wide range of materials such as concrete, render, aluminium, steel, cement and metal. A standard colour range of White, Grey, Pale Beige, and Moss Green is available.
	<i>Duratread</i>	A water based, high build trafficable membrane coating for the protection of floor surfaces. Can be applied to concrete, bitumen, steel, aluminium, metal, etc.
Polyurethane	<i>K10 Plus</i>	Single pack, water based, polyurethane waterproofing membrane for internal and external wet areas, such as showers, bathrooms, etc. Ideal for roofs, including walkways and other exposed situations. Foot trafficable.
Acrylic/Cement	<i>Dampfast</i>	2-part waterproofing and sealing membrane that eliminates the need for a primer. Quick drying. Ideal for waterproofing shower recesses, laundry rooms, roofs, water tanks, cement toppings, planter boxes, etc.
Cementitious	<i>Davco K11</i>	A brush or spray applied, cement based system for waterproofing masonry through the crystallisation process. Davco K11 is applied to the side or the negative side of the substrate and as such is suitable for areas involving negative hydrostatic pressure i.e. lift wells, cellars etc.
Bitumens	<i>Bitumen Paint</i>	A multi purpose bitumen paint which can be used as an adhesive or a surface coating.
	<i>Brushable Waterproofer</i>	A thick cold applied solvent based bitumen, reinforced with tough inert fibres to produce a non-trafficable, black, semi-flexible waterproofing membrane.
	<i>Brushable Duraseal</i>	A thick bitumen putty reinforced with tough inert fibres to produce a non-trafficable, black, semi-flexible waterproofing membrane.
	<i>Duraseal Putty (Waterproofing Putty)</i>	Putty has a thick consistency, and dries to form a thick waterproofing membrane.
	<i>Silvershield</i>	Water resistant bitumen-based coating containing flakes of aluminium for UV protection.
	<i>Aqueous Bitumen</i>	A single component, water-based emulsion of bitumen and cement solids content, formulated for coating concrete. Aqueous Bitumen forms an elastic membrane resistant to penetration of water.
	<i>Bitkote No. 3</i>	Bitkote No. 3 is suitable for general purpose repair and protection of timber, metal, brick, concrete and cement sheeted surfaces against water. It is also suitable for concrete water storage tanks, ponds etc.
<i>Bitkote No.5</i>	Bitkote No. 5 contains reinforcing fibres for sealing cracks in concrete structures and is suitable for heavy duty applications. Ideal for use on roofs and can be used as a leveling layer prior to application of a trafficable membrane.	
Miscellaneous	<i>Masonry Waterproofer</i>	A clear saturating fluid that effectively provides a barrier to water, as well as soot, dirt and mould growth. In addition, it does not alter the appearance of the substrate when used on the exterior of brickwork or render.

For help with product selection, refer to the Waterproofing Selection Guide.

Type Tested

These products have been type tested, granted by Quality Assurance Services, this certifies that the products conform with Specification no: AS3855:1994 highlighting their suitability for contact with pot



		Coverage <i>All figures quoted may vary depending on application, site conditions and the porosity of the surface.</i>	Pack Sizes
ing membrane, ting.	CSIRO Appraised	4L will cover approximately 1.5m ² when used with fibreglass matting.	4L, 10L and 20L.
use of conventional ofed.	CSIRO Appraised	15L will cover approximately <ul style="list-style-type: none"> • 10m² - to provide a 1mm thick dry film • 15m² - to provide a 0.6mm thick dry film 	4L and 15L.
the sealing and plied to all common building sheet, masonry, brick, wood etc. sion Brown is available.		<i>Flat Roofs:</i> 500 micron dry film thickness - 1.1 m ² /L. <i>Pitched Roofs:</i> 370 micron* dry film - 1.5 m ² /L <i>Walls (smooth):</i> 250 micron* dry film - 2.2 m ² /L <i>High Movement / Likely Cracking areas:</i> 1000 micron* dry film - 0.5 m ² /L <i>Junction/Joints:</i> 500 - 1100 micron* dry film - 0.5 - 1.1 m ² /L (ensure reinforcement is used).	4L and 20L.
e sealing and long-term protection, masonry, brick and wood etc.		1m ² per litre to achieve a dry film thickness of 500 microns*.	20L.
ane. Use to waterproof both, terraces and balconies. ons, as it is UV stable and		A 20L pail will cover approximately: <ul style="list-style-type: none"> • 13m² - to provide a 1mm thick dry film • 16m² - to provide a 0.8mm thick dry film • 20m² - to provide a 0.6mm thick dry film 	20L.
re need for a reinforcement layer. ries, terraces, balconies, concrete	Type Tested CSIRO Appraised	10L / 20kg of Davco Dampfast will cover approx 12m ² with a 1.5mm dry film thickness.	2L / 4kg Handy kit or 10L / 20kg unit.
ofing concrete and terproofs the positive able for applications		Ground Moisture - Approx 2kg/m ² Hydrostatic Pressure On the negative side - Approx 4kg/m ²	Davco K11 - Grey 25kg bags Cement Mix Fortifier - 5L and 20L.
asive primer or coating.		As an adhesive - approximately 4m ² /L. As a primer - approximately 7m ² /L. As a coating - approximately 7m ² /L.	500ml, 1L, 4L and 20L.
ugh inert fibres, roofing membrane.	Type Tested	1L will cover approximately 1m ² when applied at the rate of 1L / m ² .	500ml, 1L and 4L. (Also available in 20L as Brushable Duraseal.)
duce superior strength. Duraseal proof surface.		1kg will approx fill a joint 25mm x 25mm x 1.2m.	1kg, 4kg and 20kg. (It is also available in 300g cartridges - as Waterproofing Putty).
uminium for a protective silver or bitumen coatings to provide		1L will cover approx 8m ² .	1L, 4L and 20L.
rylic latex of high men provides an		20L will cover 15m ² applied with 2 coats. Each coat is applied at the rate of 0.67L / m ² .	20L.
ction. Ideal for sealing most gainst water entry. Also ideal as a		20L will cover approx 20m ² when applied at the rate of 1L / m ² (two coats each applied at the rate of 0.5L / m ²).	4L and 20L.
water tanks and other concrete or rejuvenating old bituminous n of sheet and acrylic membranes.		20L will cover approx 20m ² when applied at the rate of 1L / m ² (two coats each applied at the rate of 0.5L / m ²).	20L.
ater penetration as ter the colour of the		Approximately 9-12 m ² /L per coat	4L and 20L.

uide on the back of this brochure or call our Technical Advisory Line on 1800 653 347

1. Waterproofing Wet Areas

1.1 Shower Recesses (Category 1 Area)

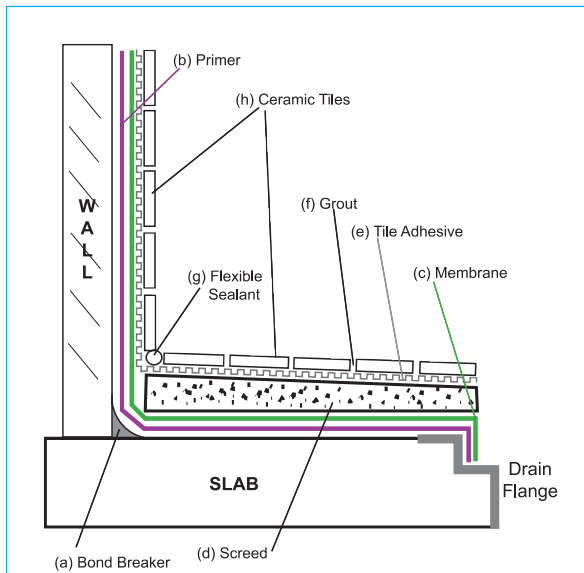

AS 3740 - Waterproofing of Wet Areas within residential buildings

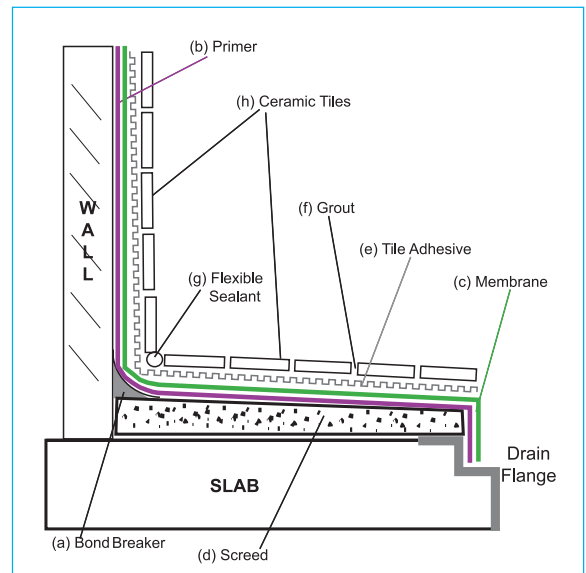

Preferred Method

- a) Use a bond breaker to create a "coved" corner detail - either Abelrod, 50mm bond breaker tape or Davsil silicone sealant.
- b) Application of primer.
- c) The Australian Standard (AS 3740 Waterproofing of Wet Areas within Residential Buildings) calls for the membrane to be applied under the screed to receive tiles, but it is recommended that the membrane be applied over the screed laid to falls.
- d) Sand Cement Screed to ensure that a minimum of 1:80 fall to the waste is created. This equates to a 12.5mm fall over 1m. Note: A slurry coat of Davelastic mixed 1:1 with neat cement should be used to improve the adhesion of the screed if being applied over the membrane.
- e) Application of Tile Adhesive.
- f) Application of Grout.
- g) Use a flexible sealant either Davsil or Colorcaulk in all wall/floor and wall/wall joints.
- h) Ceramic Tiles
- i) Drain Flange - ensure application of membrane is turned down into the drain flange.

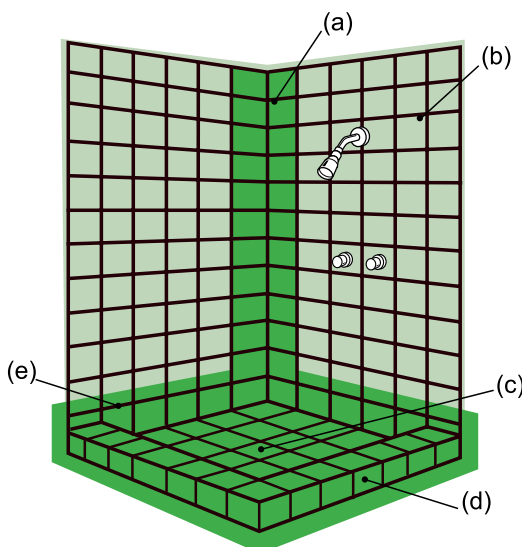

1.2 Shower Recess Detailing

- a) AS 3740 calls for the membrane to be applied up the wall to 1800mm or to the height of the shower rose, out to a width of 150mm.
- b) However, it is recommended that the entire wall is coated with the membrane, up to the height of the shower rose.
- c) Apply the membrane over the entire floor area.
- d) If enclosed by a shower screen, apply the membrane up over the hob, and at least 150mm beyond the outside edge of the hob. If unenclosed, apply the membrane up over the hob, and out to a 1500mm radius from the shower rose.
- e) Apply the membrane to the base of the wall, at least 150mm above the height of the hob.

1.3 Shower-over-bath Enclosure (Category 1 Area)

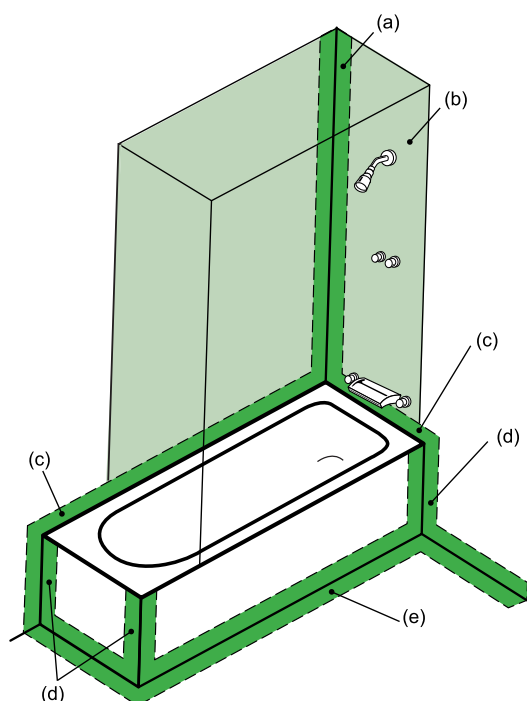

- a) AS 3740 calls for the membrane to be applied up the wall/wall junction 1800mm from the floor or to the height of the shower rose, out to a width of 150mm.
- b) However, it is recommended that the entire wall is coated with the membrane, up to the height of the shower rose.
- c) Apply the membrane 150mm wide at the base of the bath wall sheet.
- d) Apply the membrane 150mm wide over the vertical corners of the bath.
- e) Apply the membrane 150mm wide along the bath/floor joint. If the bath is enclosed with a shower screen, this will be sufficient. If the bath is unenclosed, continue applying the membrane over the floor, out to a 1500mm radius from the shower rose.

1.4 Other Wet Areas (Category 2)

1.4.1 Baths

Pedestal Bath

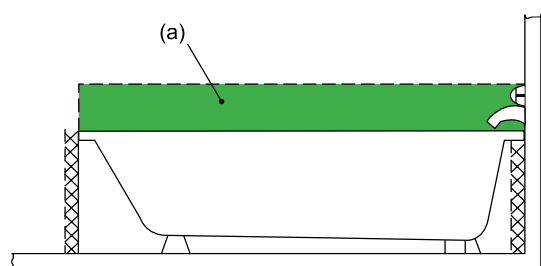

Hob Mounted Bath

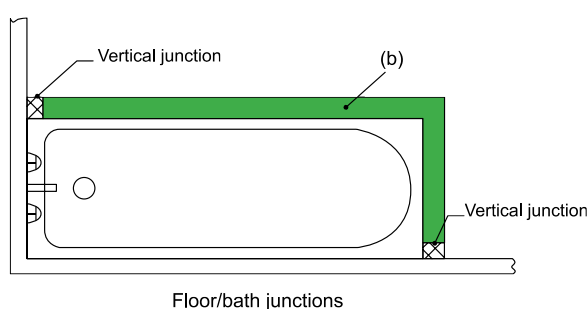

- a) Apply the membrane 150mm wide at the base of the bath wall sheet.
- b) Apply the membrane 150mm wide along the bath/floor joint.

1.4.2 Laundries, Sinks

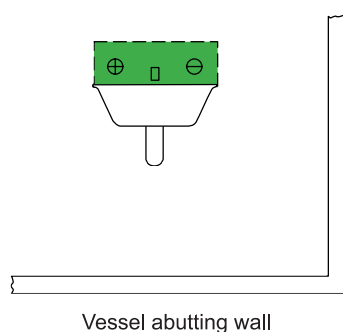

Apply membrane to the wall area 150mm above a fixed vessel, and for the width or length of the vessel.

Suitable Membranes:

- Dampflex
- Dampflex Reo
- Dampfast
- K10 Plus

2. Waterproofing, Roofs Decks and Balconies

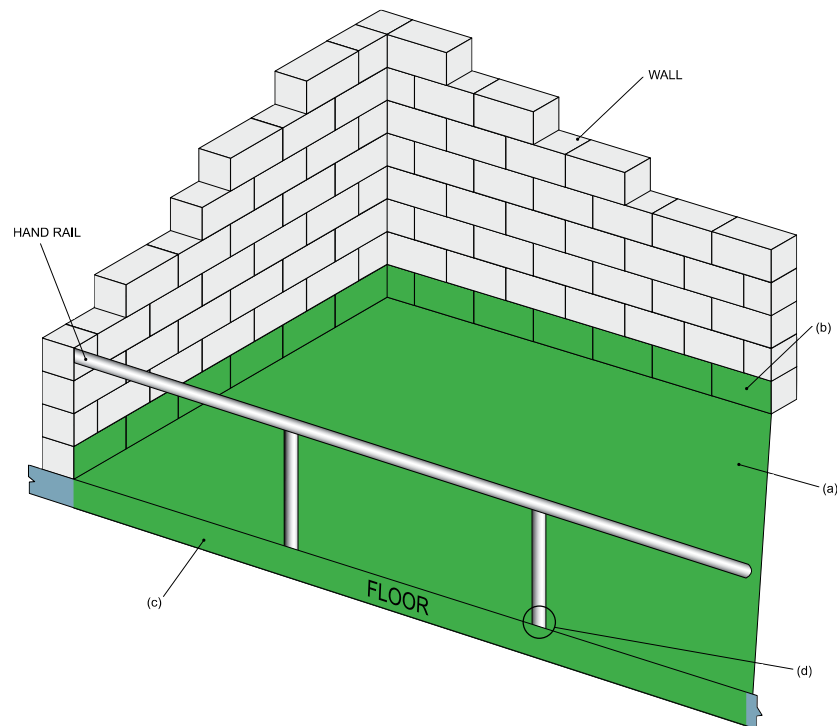

- a) Ensure the deck is constructed with falls to the edge or to the drains which are a minimum 1:100 (ie 10mm over 1m)*. If this has not been built into the floor, it will require a cement/sand screed be used to achieve this fall. Apply the membrane over the entire balcony floor, or over the screed if one has been applied.
- b) Apply the membrane up the wall at least 100mm, or to the first course of bricks.
- c) Apply the membrane over the front edge of the balcony and the underside of that front edge (if structurally possible).
- d) Ensure all gaps around handrail penetrations are carefully sealed, prior to covering with the membrane (Refer to Section 2.2.1).

* As necessary, treat any cracks or joints per instructions in Section 5.

2.1 Metal Roofs

- a) Ensure the metal surface is thoroughly cleaned and dry.
- b) Any rust needs to be removed with a wire brush or grinder. Treat with rust treatment as required.
- c) Fill any holes with Duraseal Putty (Refer to Section 4.2 for detailed hole repair).
- d) Allow to cure for 24 hours.
- e) Coat with two coats of Brushable Duraseal allowing it to cure for at least 7 days at 20°C before overcoating with Silvershield.
- f) Coat with Silvershield - allowing to dry for 24 hours at 20°C.

2.2 Rail/Pipe Penetration Details

2.2.1 Hand Rail Penetration

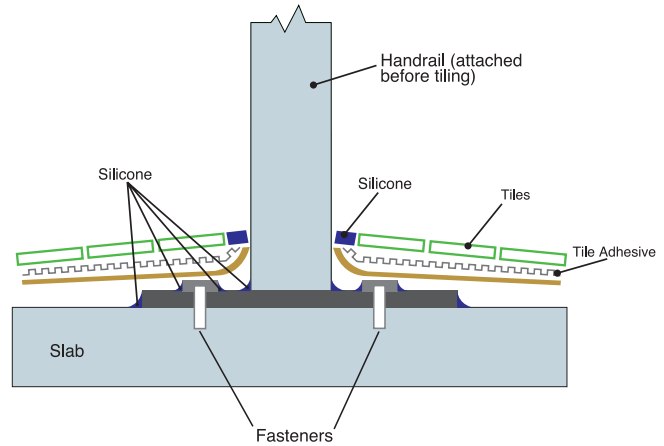
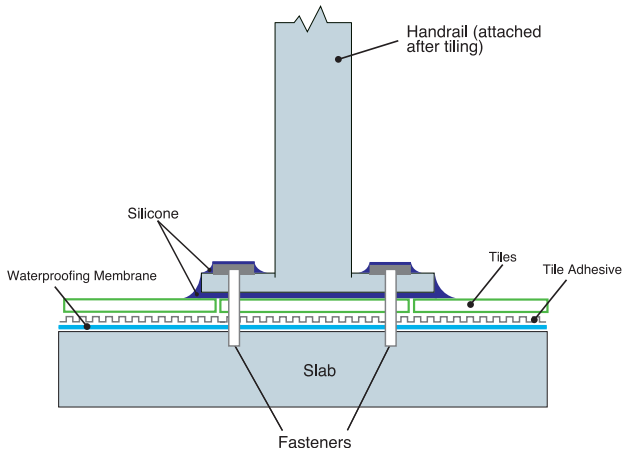

For a situation where the handrail is attached after tiling:

- Ensure the handrail and the fastening bolts are applied over one full tile.
- Apply Davsil silicone sealant around the perimeter of the base plate, the sides of the base plate and over the head of the fastening bolts, to ensure it is fully sealed.

For a situation where the handrail is attached prior to tiling:

- The membrane is turned up the penetration to the point where the tiling will finish.
- The tiles & grout would be applied.
- Davsil silicone sealant used to seal the gap between the tiles and the penetration.

2.2.2 Pipe Penetration

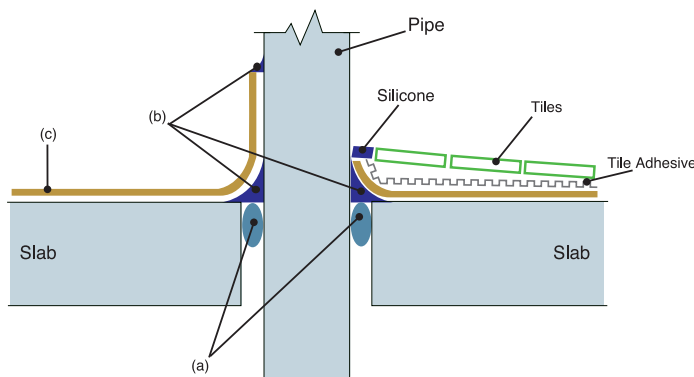

- If required, use Abelrod backer rod to fill gap between slab and pipe.
- Apply Davsil (silicone sealant) over joint to form a corner cove, and to top of the membrane to finally seal it.
- Apply membrane after use of appropriate primer over concrete slab, (and suitable primer over the pipe penetration). Membrane should be turned up the pipe 100mm.

For a situation where the balcony is to be tiled:

- The membrane is turned up the penetration to the point where the tiling will finish.
- The tiles and grout would be applied.
- Davsil Silicone sealant used to seal the gap between the tiles and the penetration.

Suitable Membranes for tiling over:

- Dampfast
- Dampflex Reo
- Davco K10 Plus
- Davco K11

Suitable Exposed Membranes:

- Brushable Duraseal/Silvershield
- Duraflex
- Duratread
- Davco K10 Plus

3. Planter Boxes

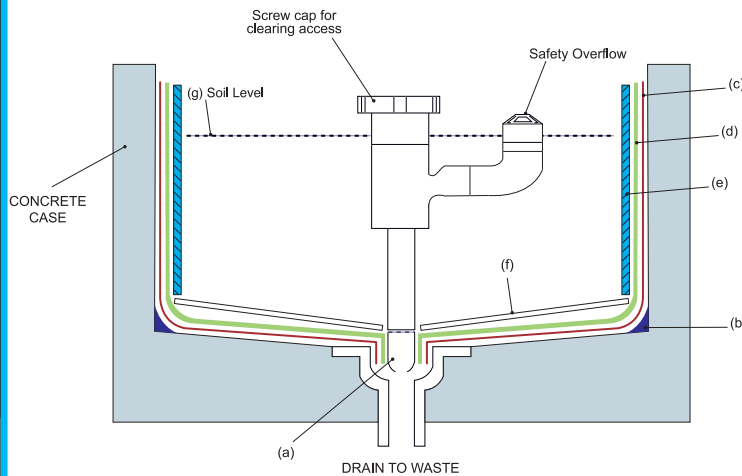

- a) Grate to stop roots going down drain waste.
- b) Davsil (silicone) or Sodaflex 603 as bond breaker in corners, allow to cure.
- * *Treat any cracks as per instructions in Section 5.*
- c) Prime with suitable primer.
- d) Apply the membrane over the entire surface.
- e) Fibre cement protection board to stop root damage to the membrane.
- f) Drainage cell - recommended that this be wrapped in geo-filter fabric, to protect the membrane from root damage, and aid in drainage of moisture to the outlet.
- g) Soil level should be 100mm below the membrane.

NOTE: The suitability of plants to be installed should be considered, as certain rooting systems are aggressive and may penetrate the membrane.

4. Water Tanks/Ponds

4.1 Concrete Tanks (Potable)

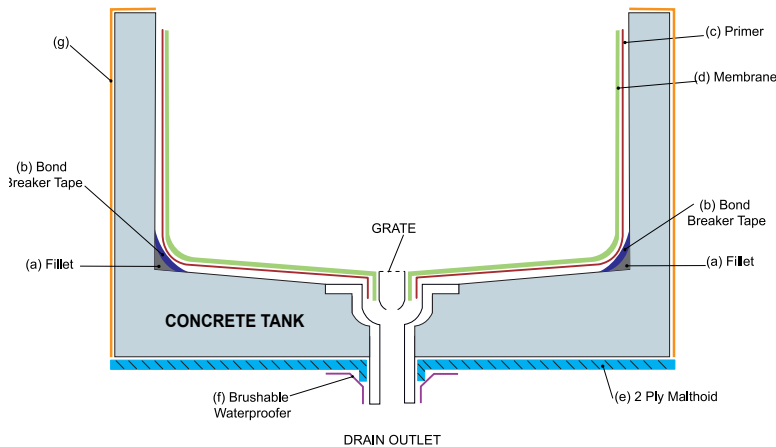

Surface Preparation

Ensure the tank is emptied and dried. If required, use a suitable biocide to remove any signs of biological growth/contamination, then allow to dry. Treat any cracks, joints as per instructions in Section 5. Ensure all sharp protrusions are removed/treated prior to application. All laitance must be removed by mechanical means. The tank needs to be thoroughly dried before starting work.

- (a) Apply a fillet into the corners using a 4:1 sand:cement screed, gauged with diluted Davelastic (mixed 1 part Davelastic to 3 parts water). Allow 24 hours to set.
- (b) Apply a bond breaker tape (eg, Duct tape), over the fillet, extending 20mm either side of fillet.
- (c) Apply primer coat over the entire tank surface. Allow to dry.
- (d) Apply 2 coats of membrane, allowing suitable drying/airing in between coats. Allow the final coat to dry for a minimum of 10 days, and then wash the membrane and allow it to dry thoroughly, at least twice, before filling.
- (e) To prevent water ingress from beneath the tank, it is recommended to sit the tank on a bed of Malthoid.
- (f) Apply a coat of Brushable Waterproofer to seal Malthoid to drain outlet and make base watertight.
- (g) It is also suggested the exterior of the tank be coated with Duraflex, a suitable exterior coating membrane system, to prevent water ingress.

4.2 Metal Tanks (Potable)

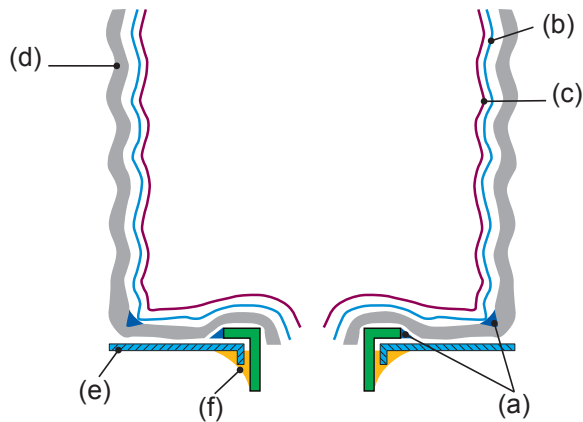

Surface Preparation

Detailed Hole Repair

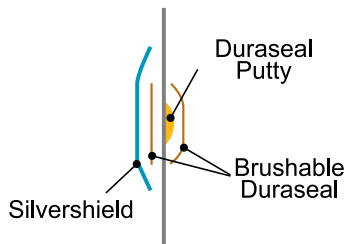

- Abrade surface with wire brush to remove any signs of rust.
- Treat with rust treatment as required.
- Fill hole with Duraseal Putty. Allow to cure 24 hours.
- Coat inside and out with Brushable Duraseal - coating 100mm radius from hole.
- Coat any Brushable Duraseal on the exterior of the tank which will be exposed to UV light with Silvershield.

General Surface Repair

- Ensure the tank is emptied, thoroughly cleaned and dry.
 - Use a suitable biocide to remove any sign of biological growth/contamination, then allow to dry.
 - Use a wire brush or grinder to remove any signs of rust and treat holes as mentioned above. Use a suitable rust treatment method as required to treat rust spots.
 - Coat the treated area - coating 100mm radius from the edge of the treated area with Brushable Duraseal.
- Apply Duraseal Putty as bond breaker onto corner, and against inside flange of drain outlet.
 - Prime entire inside using Bitumen Paint. Allow to dry 24 hours.
 - Coat tank with 2 coats Brushable Duraseal, allowing 24 hours drying between coatings. Allow the final coat to dry for a minimum of 10 days, and then wash the membrane and allow it to dry thoroughly, at least twice, before filling.
 - Apply a coating of Silvershield over the entire outside of the tank, should it require overcoating, or wherever any of the bitumen products are exposed to UV light.
 - To protect the base of the tank from moisture, it is recommended to sit the tank on a bed of Malthoid.
 - Apply a coat of Brushable Duraseal to seal the Malthoid to the drain outlet and make the base watertight.

Suitable Membranes:

- Brushable Duraseal / Silvershield
- Dampfast
- Davco K11

5. Treatment of Expansion Joints and Cracks

5.1 Non Structural Cracks (NOT Subject to Movement) < 0.5mm

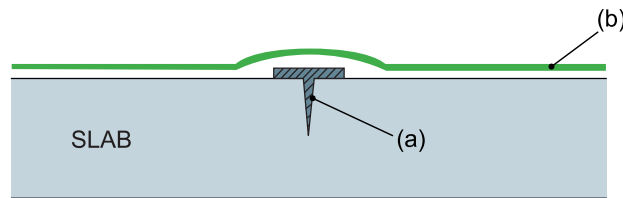

- Fill the crack with the membrane and apply a 50mm wide band of membrane over the length of the crack and allow to dry.
- Apply membrane to remainder of area, after use of suitable primer.

5.2 Non Structural Cracks (NOT Subject to Movement) > 0.5mm

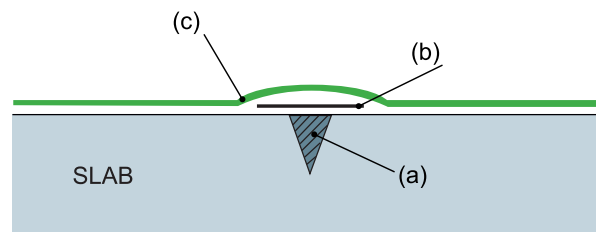

- Route out the joint to form a 'V' shaped groove with a hand or power chisel, to a depth and width of approximately 25mm. Dampen the chiselled out crack with clean water and whilst still damp, fill the joint with Lanko 731 repair mortar or Duragrout. Finish flush with the concrete surface and allow 24 hours to cure.
- Apply a 100mm band of membrane over the filled crack and allow to dry.
- Apply the membrane to the remainder of the area after use of suitable primer.

5.3 Structural Cracks (Subject to Movement)

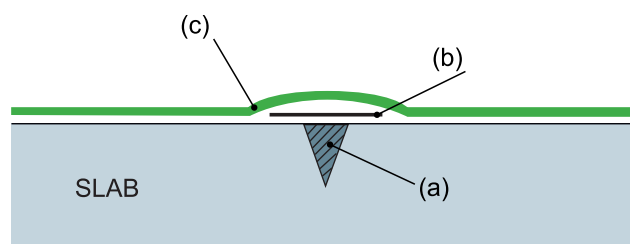

NOTE: All structural cracks should be subject to investigation by a structural engineer prior to any remedial action. We offer the following as a guide only - each case needs to be assessed on its individual merits.

- Fill the crack with a flexible sealant - Davsil (Silicone) or Sodaflex 603 (Polyurethane). Allow 24 hours to cure. In the case of large cracks, Abelrod can be used to pack the body of the crack, before filling with Davsil or Sodaflex 603.
- Apply a 100mm wide strip of Polyethylene/Polypropylene tape over the total length of the crack - extending either side of where the crack finishes. * Ensure the surface is clean prior to application of the tape, to achieve good adhesion.
- Apply the membrane to the remainder of the area after use of suitable primer.

5.4 Expansion Joints

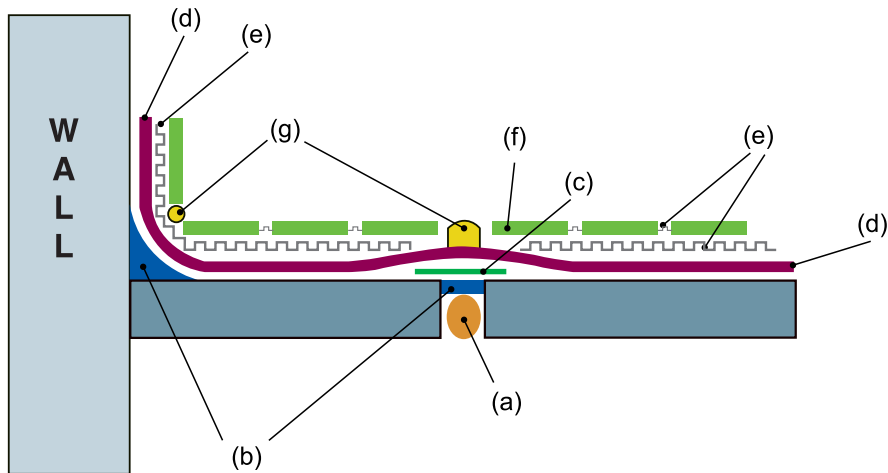

- For wide joints (>10mm), the use of Abelrod (Polyethylene foam backer rod) is recommended.
- Use Davsil (silicone) or Sodaflex 603 (Polyurethane) to fill the remainder of the joint, and to provide a bond breaker at the wall/floor junction. (Narrow joints of <10mm can be filled with Davsil or Sodaflex 603 only).
- Apply a 50mm wide strip of polyethylene/polypropylene tape over the total length of the expansion joint.
* Ensure the surface is clean prior to application of the tape, to achieve good adhesion.
- Apply the membrane to the remainder of the area, after use of a suitable primer.
- & f) Application of adhesive, tiles and grout ensuring the expansion joint is NOT tiled over.
- Use Davsil (silicone) or Sodaflex 603 (Polyurethane) to fill the expansion joint and the wall/floor joint in the tiled surface.

5.5 Sheet Joint Detail

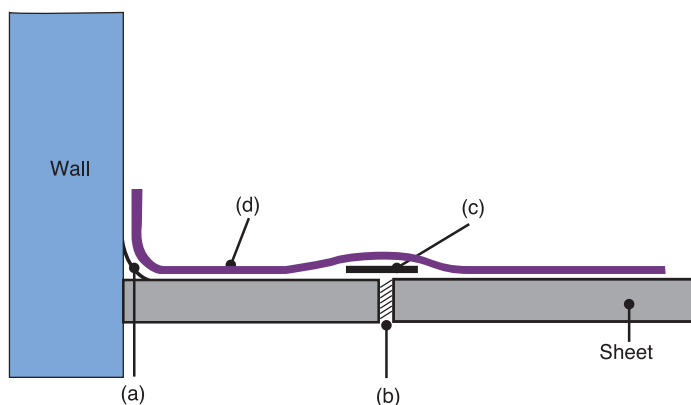

NOTE: Ensure the floor sheeting material used is suitable for the intended application - consult the manufacturer for suitability. All floor sheeting material must be fixed in accordance with the manufacturers instructions. All joint detailing must also be carried out in accordance with the manufacturers instructions. In the absence of suitable instructions for joint detailing we offer the following suggestion, however this does not override manufacturers instructions:

- Davsil (Silicone) or Sodaflex 603 (Polyurethane) bond breaker.
- Davsil or Sodaflex 603 in sheet joint, if the joint is greater than 1mm. For butt jointed sheets, or joints of less than 1mm, the use of a flexible sealant is not necessary.
- Polyethylene/Polypropylene tape - 50mm wide, to be placed over all joints, prior to application of membrane (including joints of less than 1mm). * Ensure the surface is clean prior to application of the tape, to achieve good adhesion.
- Apply membrane, after use of a suitable primer.

Davco Waterproofing Selection Guide

		MEMBRANE OVERCOATED OR COVERED WITH.....					EXPOSED MEMBRANE	
SUBSTRATE		Paint or other membrane	Tiles	Pavers	Vinyl	Timber floorboards (floating)	Light Foot Traffic (Building Maintenance)	Foot Traffic (Entertaining Areas)
Roofs & Decks								
Concrete Slab	Dampflex Dampflex Reo K10 Plus	K10 Plus Dampflex Dampflex Reo Dampfast	K10 Plus Dampflex Dampflex Reo Dampfast	Duraflex Dampflex Reo K10 Plus	K10 Plus Dampflex Dampflex Reo Dampfast	Duraflex Dampflex Reo K10 Plus	Duraflex K10 Plus Dampfast	Duratread
Metal (primed)	Duraflex K10 Plus	Duraflex Dampflex Reo K10 Plus	Duraflex Dampflex Reo K10 Plus	Duraflex Dampflex Reo K10 Plus	Duraflex Dampflex Reo K10 Plus	Duraflex K10 Plus Brushable Duraseal/Silvershield	Duraflex K10 Plus	Duratread
Compressed FC Sheet Timber Marine Grade Plywood	Dampflex Dampflex Reo K10 Plus	Dampflex Dampflex Reo K10 Plus	Dampflex Dampflex Reo K10 Plus	n/a	Dampflex Dampflex Reo K10 Plus	Duraflex K10 Plus Dampflex Dampflex Reo K10 Plus	Duraflex K10 Plus Dampfast	
Wet Areas - Showers, Bathrooms & Laundries								
Concrete Slab	n/a	K10 Plus Dampflex Dampflex Reo Dampfast	K10 Plus Dampflex Dampflex Reo Dampfast	n/a	K10 Plus Dampflex Dampflex Reo Dampfast	n/a	n/a	
Cement Render								
Cement Screed								
Compressed FC Sheet (Floors) Gypsum Plasterboard (Walls) FC Sheet (Walls)	n/a	Dampflex Dampflex Reo K10 Plus	Dampflex Dampflex Reo K10 Plus	n/a	Dampflex Dampflex Reo K10 Plus	n/a	n/a	
Immersed Areas - Swimming Pools								
Concrete	Dampfast Davco K11	Dampfast Davco K11	Dampfast Davco K11	n/a	n/a			
Cement Screed								
Retaining Walls, Landscaping							Planter Boxes	
Concrete	Davco K11 Bitkote No. 5 Brushable Waterproof	Dampfast Davco K11	Dampfast Davco K11	Dampfast Davco K11 Bitkote No. 5 Brushable Waterproof	n/a	n/a	Dampfast Davco K11 Brushable Duraseal/Waterproof	
Cement Render								
Cement Screed								
Water Tanks / Ponds								
Concrete	Brushable Duraseal Bitkote No. 5 Dampfast Davco K11	Brushable Duraseal Bitkote No. 5 Dampfast Davco K11	Brushable Duraseal Bitkote No. 5 Dampfast Davco K11	Brushable Duraseal Bitkote No. 5 Dampfast Davco K11	Brushable Duraseal Bitkote No. 5 Dampfast Davco K11	Brushable Duraseal Bitkote No. 5 Dampfast Davco K11	Brushable Duraseal Bitkote No. 5 Dampfast Davco K11	Brushable Duraseal Bitkote No. 5 Dampfast Davco K11
Metal (primed)	Brushable Duraseal	Brushable Duraseal	Brushable Duraseal	Brushable Duraseal	Brushable Duraseal	Brushable Duraseal	Brushable Duraseal	Brushable Duraseal

These products are suitable for waterproofing the inside of concrete tanks. Should Brushable Duraseal be in a situation where it is exposed to UV, it will need to be overcoated with Silvershield. If Bitkote No.5 is in a position where it is exposed to UV, it should be overcoated with Duraflex. For potable applications, Brushable Duraseal or Dampfast are the only suitable membranes for use.

Brushable Duraseal is recommended for waterproofing the inside of metal tanks, and is suitable for use in potable situations. Should it be in a situation where it is exposed to UV, it will need to be overcoated with Silvershield.



Davco Construction Materials Pty Limited
 ABN 28 093 876 536
 67 Elizabeth Street/Wetherill Park NSW Australia 2164
 Telephone: 61 2 9616 3000 Facsimile: 61 2 9725 5551
 Toll Free Technical Advisory Line: 1800 653 347
 Offices: Sydney, Melbourne, Brisbane & Singapore
 Email: marketing@davco.com.au Website: www.davco.com.au

This is a guide for use in the selection of waterproofing membranes only, it is not intended as a guide for building design. For detailed information or assistance on applications not covered by this guide, refer to the datasheets or contact our Technical Advisory Line 1800 653 347